

F. Bušenje i proširivanje / Drilling / Сверление и развертка

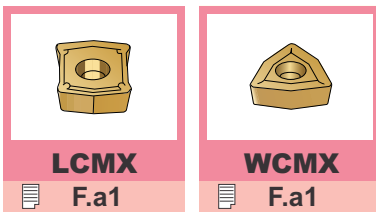

LCMX

F.a1

WCMX

F.a1

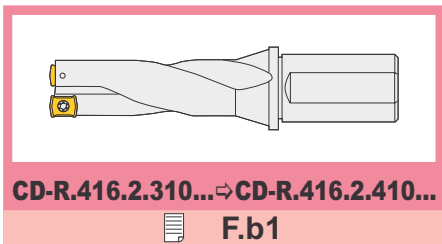

CD-R.416.2.310... → CD-R.416.2.410...

F.b1

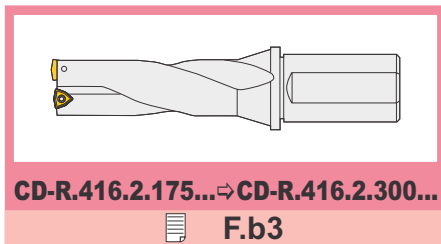

CD-R.416.2.175... → CD-R.416.2.300...

F.b3

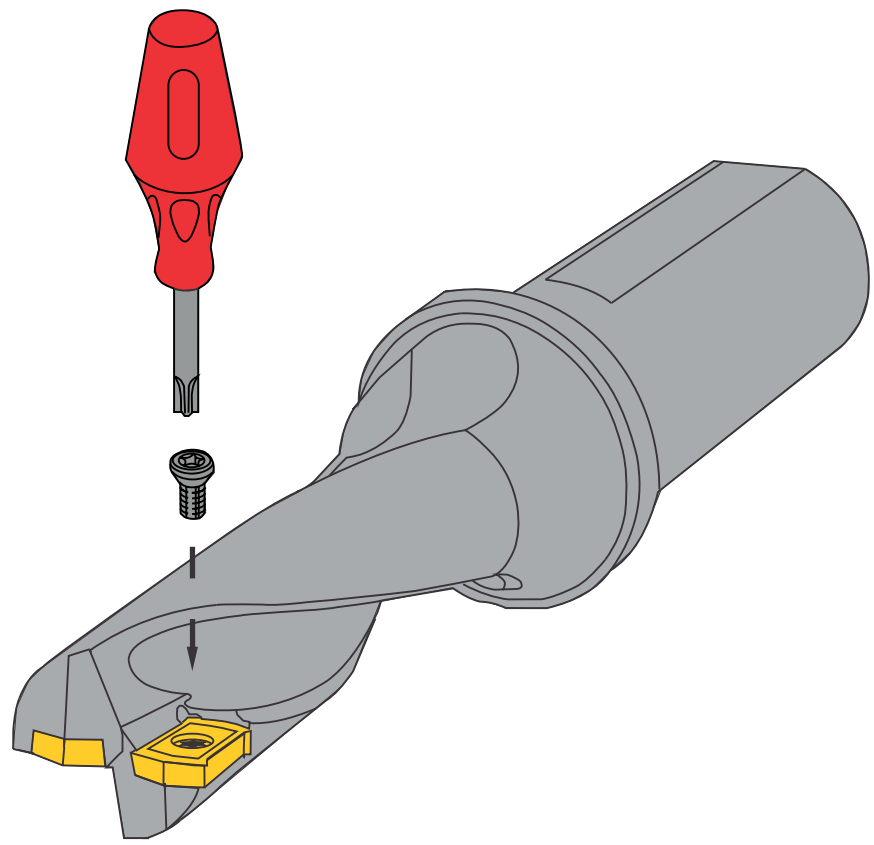

F

OPERACIJE	OPERATIONS	ОПЕРАЦИИ

**F
a.1**



F. Bušenje i proširivanje / Drilling / Сверление и развертка

F.a.Pločice za kratka bušenja / Inserts for short drilling / Пластины для краткости сверлящие

S-MAX U		LCMX		Kataloška oznaka Ordering code Обозначение пластин	Sorte / Grades / Марки сплавов														
					Presvučene Coated С покрытием					Nepresvučene Uncoated Без покрытия									
Dimenzije Dimensions Размер		l	d ₁	s	r	235	435	415	4025	4035	PMA	PM30	P-IP	PM	P6	K13A	KM	K1P	K20
3	3.25	2.5	3.18	0.8	LCMX 030308-53	○	●								○				
4	4.00	2.8	3.18	0.8	LCMX 040308 -53	○	●								○				

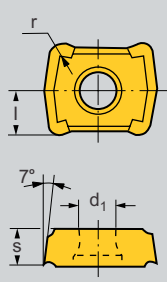

● Prvi prioritet/First choice/Первый выбор ○ Drugi prioritet/Second choice/Второй выбор ○ Po porudžini/Third choice/По договоренности

S-MAX U		WCMX		Kataloška oznaka Ordering code Обозначение пластин	Sorte / Grades / Марки сплавов														
					Presvučene Coated С покрытием					Nepresvučene Uncoated Без покрытия									
Dimenzije Dimensions Размер		l	d ₁	s	r	235	435	415	4025	4035	PMA	PM30	P-IP	PM	P6	K13A	KM	K1P	K20
6	6.14	3.7	3.97	0.8	WCMX 06T308 R-53	○	○		●						○				

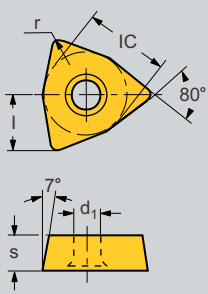

● Prvi prioritet/First choice/Первый выбор ○ Drugi prioritet/Second choice/Второй выбор ○ Po porudžini/Third choice/По договоренности



F

**F
a.1**

F. Bušenje i proširivanje / Drilling / Сверление и развертка

F.b.Alati za kratka bušenja / Tools for short drilling / Инструменты, для краткости сверлящие

CD-R.416.2.175... → CD-R.416.2.300...

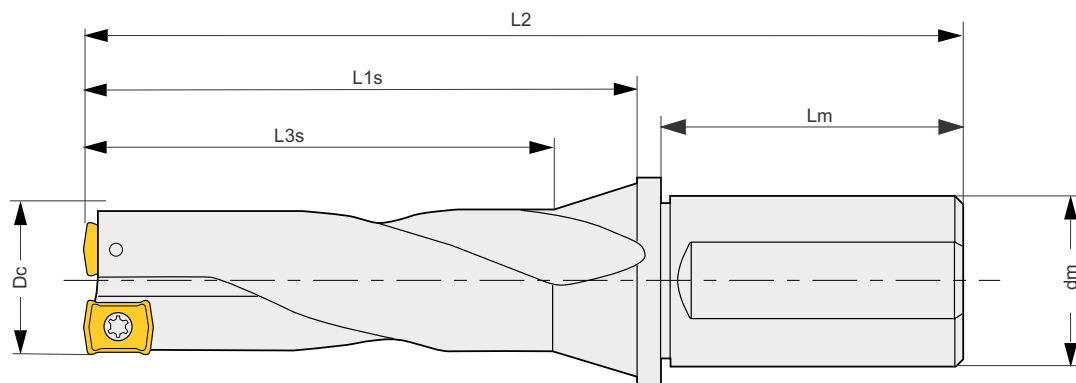

Naz. prečnik Drill diameter Диаметр D_c (mm)	Šifra Code Обозначение	Dimenzije mm / Dimensions mm / Размер мм					Plošice Inserts Пластины
		L_{3s}	L_{1s}	L_2	d_m	L_m	
17.5	CD-R.416.2-175C25.3D	64	75	135	25	55	LCMX 03
18.0	CD-R.416.2-180C25.3D						
18.5	CD-R.416.2-185C25.3D						
19.0	CD-R.416.2-190C25.3D						
20.0	CD-R.416.2-200C25.3D						
21.0	CD-R.416.2-210C25.3D	79	95	155	25	55	LCMX 04
22.0	CD-R.416.2-220C25.3D						
23.0	CD-R.416.2-230C25.3D						
24.0	CD-R.416.2-240C25.3D						
25.0	CD-R.416.2-250C25.3D						
26.0	CD-R.416.2-260C32.3D	94	110	175	32	60	
27.0	CD-R.416.2-270C32.3D						
28.0	CD-R.416.2-280C32.3D						
29.0	CD-R.416.2-290C32.3D						
30.0	CD-R.416.2-300C32.3D						

F

Naz. prečnik Drill diameter Диаметр d_c (mm)	Rezervni delovi / Spare parts / Запасные части			
	Ključ (veličina, mm) Key (size, mm) Ключ	Vijak Screw Винт	Broj Number Число PCS	
17.5-20.0	416.1-860 (T07)	5513 020-05 (M2.2)	2	
21.0-30.0	416.1-860 (T07)	5513 020-03 (M2.2)	2	

CORUN

F
b.1

Izbor sorte pločica za bušenje
 Grades for drill inserts
 Выбор сорти пластины для сверления и развертка

	ISO	ANSI	Osnovne sorte/Basic grades/ Основные сорте	Dopunske sorte/Supplementary grades Дополнительные				
P	01	C8				▲		
	10	C7						
	20		2C25	520	620	720		
	30	C6						
	40	C5		2C40				
	50			7535				
M	10	—				▲		
	20	—	2C25	620	720	7520		
	30	—		2C40	620	K13A		
	40	—						
K	01	C4				▲		
	10	C3						
	20	C2	2C25	520	620	720	K13A	
	30	C1						
	40			7535				
N						▲		
			520	620	720	K13A		
S						▲		
			520	620	720	K13A		
H						▲		
			2C25	520	620	720		